

SCROLL COMPRESSORS

SF 1-6 (1.5-5.5 kW/2-7.5 hp) / SF+ 2-22 (2.2-22 kW/3-30 hp)



Atlas Copco





COST-EFFICIENT, HIGH-QUALITY AIR

With its state-of-the-art oil-free compressor technologies such as screw, tooth, centrifugal, reciprocating and scroll, Atlas Copco provides the right solutions for your specific needs. As oil-free compressed air is a prerequisite for many manufacturing processes, we ensure consistent oil-free air by preventing oil from entering your compressed air system.

The SF and SF+ ranges of oil-free scroll air compressors unite Atlas Copco's vast experience and knowledge in a class-leading package. Whereas the SF range includes a standard pneumatic controller, the SF+ range boasts the high-end Elektronikon® controller. Reliable and compact, they both answer your demands through innovative technologies and supreme energy efficiency without compromising on quality.



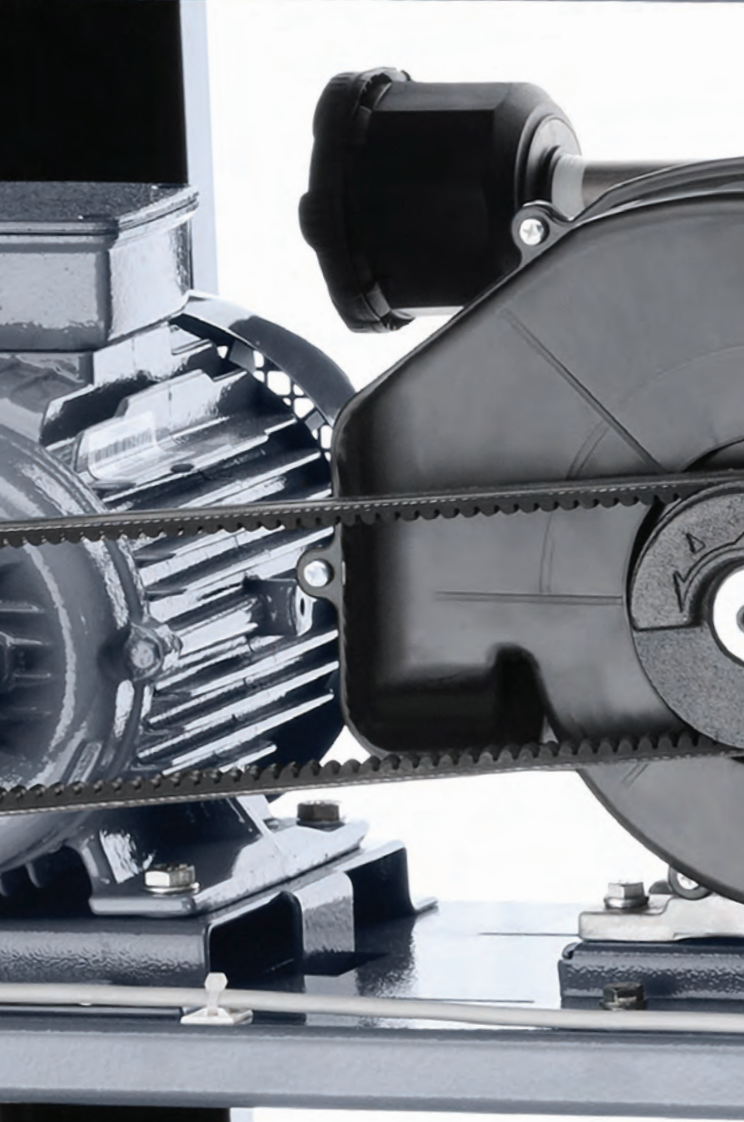
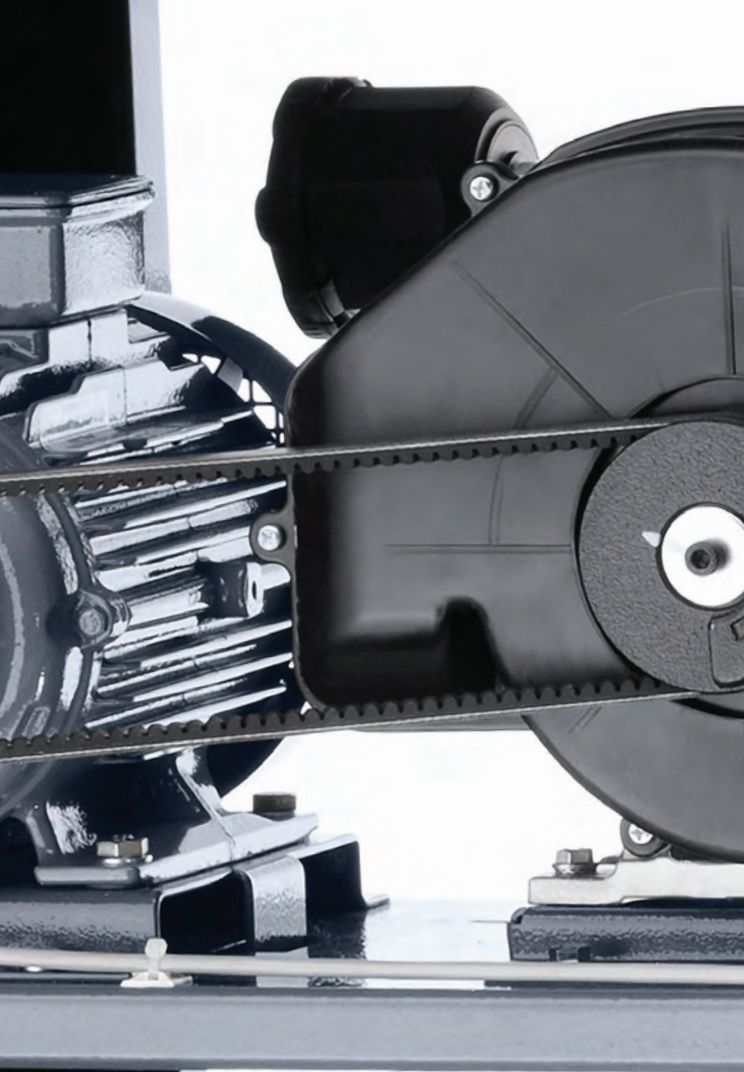

PURE OIL-FREE AIR

As there is no metal-to-metal contact between the compression scrolls, there is no need for oil lubrication in the compression chamber. Therefore, the scroll compression principle guarantees high-quality, oil-free air. As a result, the SF compressor is oil-free in every way.

ENERGY EFFICIENCY

The SF scroll compressors, standard equipped with IE3 Premium efficiency motors, are suited for sensitive applications which require flexibility and energy efficiency. Unloaded power consumption is eliminated thanks to the simple start/stop control. Advanced scroll technology guarantees an optimal free air delivery and low duty cycle applications.

EXTREMELY LOW NOISE LEVEL

The slow speed of the scroll compression elements ensures that the SF scroll compressors are extremely quiet. Sound levels are as low as 53 dB(a), making the SF the perfect choice for your sensitive working environment.

SIMPLICITY AND RELIABILITY

The SF scroll compressors stand for simplicity and reliability. The compressor has a minimal number of moving parts, ensuring a long operating life with limited service interventions. With their integrated design, Atlas Copco's SF scroll compressors have a minimal footprint and offer easy serviceability.

PROVEN PEACE OF MIND

For over sixty years, Atlas Copco has been leading the industry in oil-free compressed air technology, drawing on vast experience and continuous technological innovations. You can rest assured at all times: severe certification and testing procedures are conducted to ensure air is supplied to the highest standards of quality control.

SF 1-6/SF+ 2-6: EFFICIENT, SILENT & COMPACT

The SF 1-6/SF+ 2-6 is a complete package uniting the element, drive motor, aftercooler and starter in a super silent acoustic enclosure to be installed directly into your work environment. It is also available as a Full Feature unit with integrated refrigerant air dryer. Three receiver mounting options are available: with an extended canopy that includes three integrated 10 liter galvanized air receivers or mounted on an internally coated 270 liter (72 gallon) or 500 liter (132 gallon) horizontal receiver.

1

Air inlet filter

High efficiency paper cartridge air inlet filter, eliminating dust and particles down to 1 µm.

2

Automatic regulation

Automatic stop when the required working pressure is reached, avoiding unnecessary energy costs.

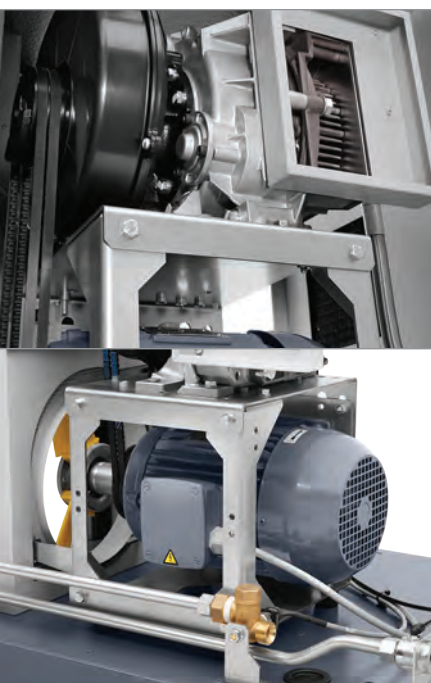

3

High efficiency scroll element

Air-cooled scroll compressor element offering proven durability and reliability in operation, in addition to solid efficiency.

4

IP55 Class F/IE3 motor

Totally enclosed air-cooled IP55 Class F motor, complying with IE3 & Nema Premium efficiency standards.



5

Refrigerant dryer

Compact & optimized integrated refrigerant dryer, ensuring the delivery of dry air, preventing rust and corrosion in your compressed air network.

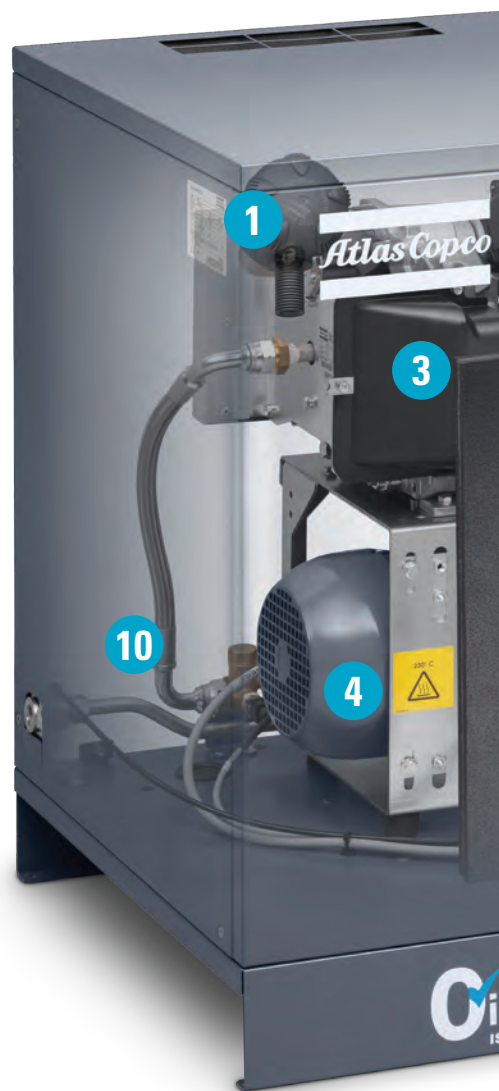



6

Silent canopy

A sound insulated canopy makes extremely low noise levels as low as 53 dB(A) possible, allowing to install the unit closer to the point of use.

7

Integrated receiver

Plug and play solution, lower installation costs with 30l, 270l and 500l tank-mounted options.

8

Elektronikon® (SF+)

Monitoring features include warning indications, maintenance scheduling and online visualization of running conditions.

9

Innovative design

The new compact vertical setup enables easy access for maintenance, improves cooling allowing lower working temperatures and provides vibration damping.

10

Cooler & piping

- An oversized cooler improves the performance of the unit.
- The use of aluminum pipes and the vertically oversized check valve improve reliability over lifetime and assure the high quality of your compressed air.



SF-Skid/Twin

- Suitable for installation at the point of use or for integration into an existing air network: designed with simplicity in mind.
- Self-contained units equipped with a single scroll element, drive motor, aftercooler and integrated starter, all contained in a modern silenced acoustic canopy.



SF+ 8-22: MODULAR & FLEXIBLE

SF+ 8-22 multi-scroll units bring in the benefits and flexibility of a modular system utilizing two to four compressor modules integrated into one canopy. The Elektronikon® continuously monitors the status of each element and starts and stops the compression elements, thereby ensuring that the compressed air output matches the air demand. Moreover, the perfect air quality and user-friendliness of these units guarantee a superior production process.

1 Air inlet filter

High efficiency paper cartridge air inlet filter eliminating dust and particles down to 1µm.

2 IP55 Class F IE3 motor

Totally enclosed & air-cooled IP55 Class F motors, complying with IE3 Premium efficiency standards.



3 High efficiency scroll element

Air-cooled scroll compressor elements with 8 and 10 bar variants, offering proven durability and reliability in operation, in addition to superior efficiency.

4 Refrigerant dryer

Compact & optimized integrated refrigerant dryer ensuring the delivery of dry air, preventing rust and corrosion in the installed compressed air network.

5 Silent canopy

Thanks to the low-noise scroll element, optimized super-silent fan and sound-insulated canopy, best in class noise levels possible are achieved.

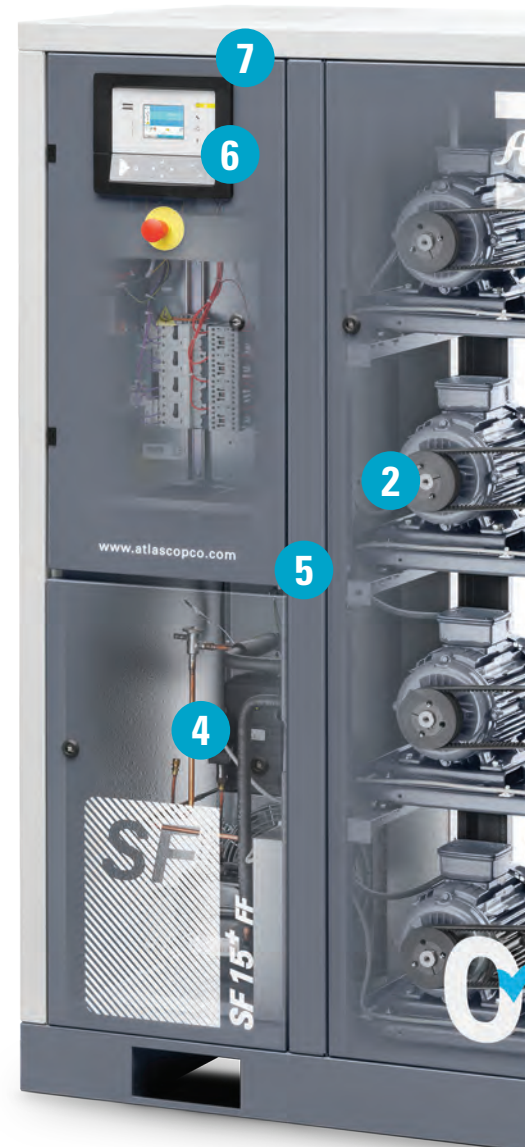



6

Elektronikon® Mk5 Graphic

While running the VFT algorithm, the Elektronikon® Mk5 Graphic matches the required air demand, eliminating unload power consumption.



7

Optimized cooler & piping

The air cooler is finetuned for improved performance, while the use of aluminum & stainless steel pipes improve reliability over lifetime and assure the high quality of compressed air.

8

Smart design

Outstanding user-friendly design, with safety in operation & ease of serviceability in mind.

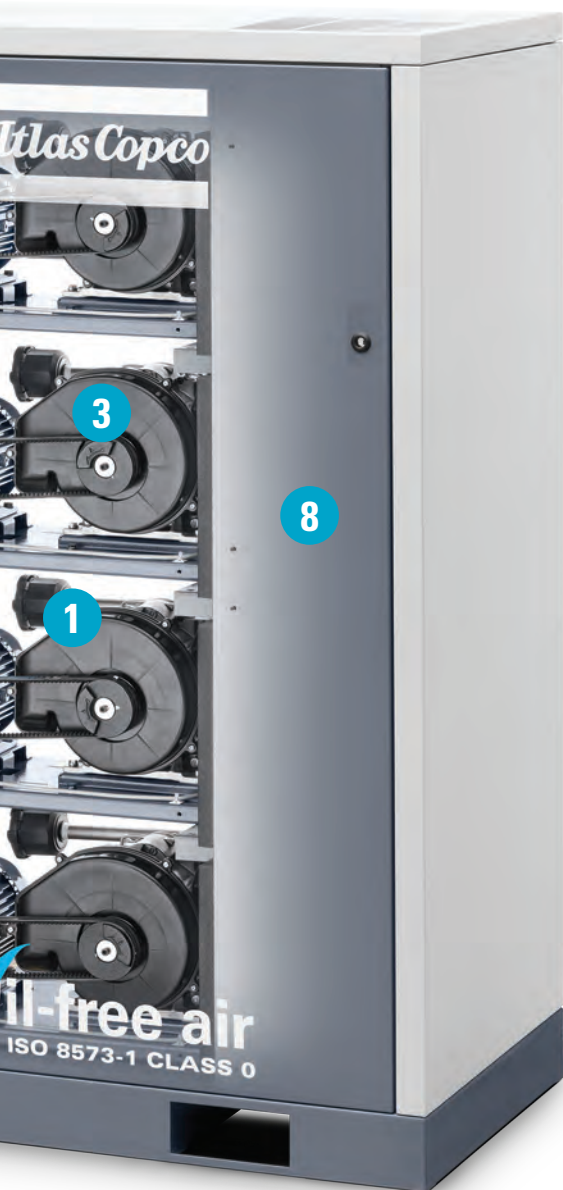

SF Duplex

- Duplex set-up with two cubicles, one/two main modules and one/two modules as back-up.
- Elektronikon® regulates each set of compressor modules via an integrated central control system.
- Enclosed in sound-insulated bodywork.





CLASS 0: THE INDUSTRY STANDARD

Oil-free air is used in all kinds of industries where air quality is paramount for the end product and production process. These applications include food and beverage processing, pharmaceutical manufacturing, chemical and petrochemical processing, fermentation, wastewater treatment, pneumatic conveying, non-woven textile manufacturing and many more. In these critical environments, contamination by even the smallest quantities of oil can result in costly production downtime and product spoilage, resulting in product recalls and loss of reputation.

First in oil-free air technology

Over the past sixty years Atlas Copco has pioneered the development of oil-free air technology, resulting in a range of air compressors and blowers that provide 100% pure, oil-free air. Through continuous research and development, Atlas Copco achieved a new milestone, setting the standard for air purity as the first manufacturer to be awarded ISO 8573-1 Class 0 certification.

Eliminating any risk

As the industry leader committed to meeting the needs of the most demanding customers, Atlas Copco requested the renowned TÜV institute to type-test its range of oil-free compressors and blowers. Using the most rigorous testing methodologies available, all possible oil forms were measured across a range of temperatures and pressures. The TÜV found no traces of oil at all in the output air stream. Thus Atlas Copco is the first compressor and blower manufacturer to receive Class 0 certification, according to ISO 8573-1 Class 0 Ed. 3 2010 specifications.

CLASS	Concentration total oil (aerosol, liquid, vapor) mg/m ³
0	As specified by the equipment user or supplier and more stringent than class 1
1	< 0.01
2	< 0.1
3	< 1
4	< 5

Current ISO 8573-1 (2010) classes (the five main classes and the associated maximum concentration in total oil content).

ADVANCED SCROLL TECHNOLOGY

Solid efficiency is a distinctive advantage of the Atlas Copco SF series, thanks to the unique working principle of scroll technology. Air compression is achieved by the interaction of a fixed and orbiting scroll. Air at inlet pressure enters the compression chamber at the exterior side of the scroll element. Once air is drawn in, the orbiting scroll seals off the inlet port. As the scroll continues to orbit, the air is progressively compressed into an increasingly smaller 'pocket'. A continuous flow of compressed air leaves the scroll element through a discharge port in the center of the fixed scroll. This process is continuously repeated, resulting in the delivery of pulse-free compressed air.

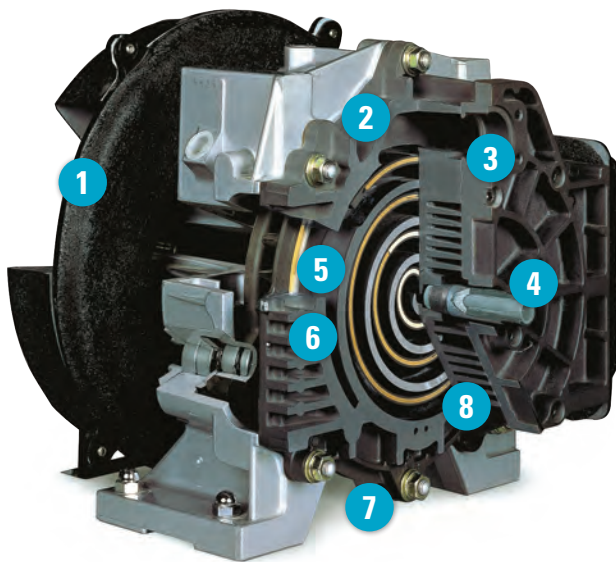

- 1 Cooling fan
- 2 Suction chamber
- 3 Suction opening
- 4 Delivery opening
- 5 Fixed scroll
- 6 Orbiting scroll
- 7 Fail-safe temperature sensor for unit protection
- 8 Compression chamber

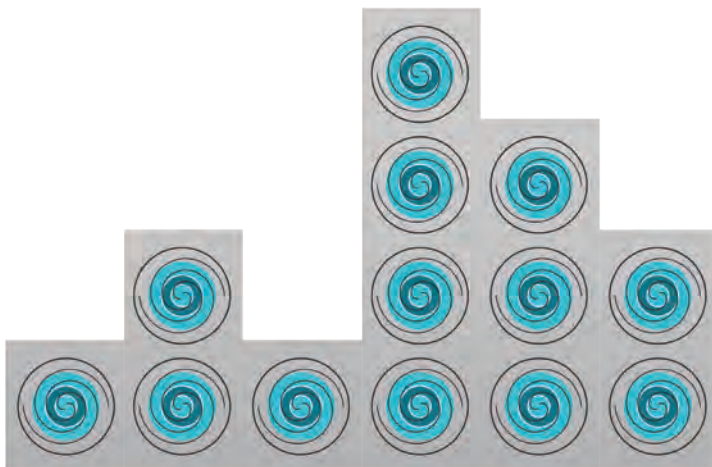
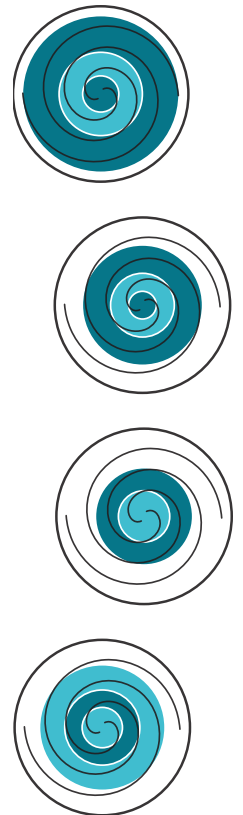

Variable flow technology (VFT)

All SF+ 8-22 multi-scroll compressors are equipped with the unique VFT control system, which provides maximum flexibility of air delivery. The VFT system, included in the Elektronikon® controller, automatically starts and stops the scroll elements to exactly match the demands of your compressed air system. The Elektronikon® control algorithm ensures that the system pressure is kept within a very narrow pressure band which optimizes the compressor's efficiency and guarantees a very stable system pressure. The Elektronikon® also gives an instant read out of all operational data and continuously scans and monitors the operation of the SF.

WORKPLACE AIR SYSTEM™ COMPRESSORS: THE SOUND OF SILENCE

Atlas Copco WorkPlace Air System™ compressors are much more than low noise air compressors with integrated air treatment equipment. To help you save energy and costs, they are designed to give the most efficient source of compressed air within a production environment.



Quiet and compact

A low noise level enables the compressor to be installed close to the compressed air application, minimizing the size of the air distribution system and reducing pressure loss and the potential for leakage.



A solution that fits

Thanks to the broad range of Atlas Copco air treatment technology, you can select the most efficient system to meet your specific compressed air requirements.



Cost-saving

As the air treatment is completely integrated, the installation costs are substantially reduced, making multiple compressor installations practical and financially viable.



Supreme energy efficiency

To ensure maximum energy efficiency, Atlas Copco offers both traditional on/off regulating systems where the air demand is constant.



Peace of mind

With the SF, Atlas Copco does not just offer the most reliable and efficient compressors. From air quality solutions to a complete piping installation, Atlas Copco can take responsibility of your entire compressed air system to provide you with best-in-class air. Choose from a wide range of Atlas Copco after sales products and services that will have your SF performing at its best for years to come. Qualified Atlas Copco support is available in over 180 countries.

A STEP AHEAD IN MONITORING AND CONTROLS

The next-generation Elektronikon® operating system offers a wide variety of control and monitoring features that allow you to increase your compressor's efficiency and reliability. To maximize energy efficiency, the Elektronikon® controls the main drive motor and regulates system pressure within a predefined and narrow pressure band. The SF+ 2-6 are equipped with a standard Elektronikon® controller, while the SF+ 8-22 come with the advanced Elektronikon® Graphic.



Improved user-friendliness

- 3.5-inch high-definition color display with clear pictograms and extra 4th LED indicator for service.
- Graphical display of key parameters (day, week, month) and 32 language settings.
- Internet-based compressor visualization using a simple Ethernet connection.
- Graphical indication Serviceplan, remote control and connectivity functions.
- Software upgrade available to control up to 6 compressors by installing the optional integrated compressor controller.

Online & mobile monitoring

Monitor your compressors over the Ethernet with the new Elektronikon® controller. Monitoring features include warning indications, compressor shut-down and maintenance scheduling. The Atlas Copco App is available for iPhone/Android phones as well as iPad and Android tablets. It allows fingertip monitoring of your compressed air system through your own secured network.



SMARTLink

- Remote monitoring system that helps you optimize your compressed air system and save energy and costs.
- Provides a complete insight in your compressed air network.
- Anticipates on potential problems by warning you up-front.



TECHNICAL SPECIFICATIONS

TYPE	Max. working pressure		Capacity FAD*			Installed motor power		Noise level**	Weight	
	bar(e)	psig	l/s	m ³ /min	cfm	kW	hp	dB(A)	kg	lbs
SF 1-6/2*-6* (50/60 Hz)										
SF 1	8	116	2.9	0.17	6.1	1.5	2	53	120	265
	10	145	1.9	0.11	4.0	1.5	2	53	120	265
SF 2 / SF 2*	8	116	4.2	0.25	8.9	2.2	3	55	125	276
	10	145	3.4	0.20	7.2	2.2	3	55	125	276
SF 4 / SF 4*	8	116	6.7	0.40	14.2	3.7	5	57	133	293
	10	145	5.9	0.35	12.5	3.7	5	57	133	293
SF 6 / SF 6*	8	116	9.8	0.59	20.8	5.5	7.5	59	157	346
	10	145	7.6	0.46	16.1	5.5	7.5	59	157	346
SF 8*-22* (50/60 Hz)										
SF 8*	8	116	13.4	0.80	28.4	8	10	63	372	820
	10	145	11.4	0.68	24.2	8	10	63	372	820
SF 11*	8	116	20.3	1.22	43.0	11	15	63	418	921
	10	145	15.0	0.90	31.8	11	15	63	418	921
SF 15*	8	116	26.4	1.58	55.9	15	20	63	550	1212
	10	145	23.0	1.38	48.7	15	20	63	550	1212
SF 17*	8	116	31.0	1.86	65.7	17	22	64	565	1245
	10	145	23.7	1.42	50.2	17	22	64	565	1245
SF 22*	8	116	40.8	2.45	86.5	22	30	65	650	1433
	10	145	30.0	1.80	63.6	22	30	65	650	1433
SFD 11*-22* (50/60 Hz)										
SFD 11*	8	116	9.8	0.59	20.8	11	15	63	625	1380
	10	145	7.6	0.46	16.1	11	15	63	625	1380
SFD 15*	8	116	13.4	0.80	28.4	15	20	64	755	1665
	10	145	11.4	0.68	24.2	15	20	64	755	1665
SFD 22*	8	116	19.2	1.21	42.8	22	30	65	840	1855
	10	145	15.0	0.90	31.8	22	30	65	840	1855
SF SKID/TWIN										
Skid versions										
SF 1	8	116	2.9	0.17	6.1	1.5	2	65	105	232
	10	145	1.9	0.11	4.0	1.5	2	65	105	232
SF 2	8	116	4.2	0.25	8.9	2.2	3	67	110	243
	10	145	3.4	0.20	7.2	2.2	3	67	110	243
SF 4	8	116	6.6	0.40	14.0	3.7	5	68	120	265
	10	145	5.6	0.34	11.9	3.7	5	68	120	265
Twin versions - duplex tank mounted										
SF 6T	8	116	10.6	0.64	22.5	5.9	8	72	365	805
	10	145	9.0	0.54	19.1	5.9	8	72	365	805
SF 8T	8	116	13.2	0.79	28.1	7.4	10	73	375	827
	10	145	11.2	0.67	24.8	7.4	10	73	375	827

* Unit performance measured according to ISO 1217, Annex C, Latest Edition.

** Mean noise level measured at a distance of 1 m according to ISO 2151, tolerance 3 dB(A).
Weights of the pack & floor-mounted units are shown in the chart.

DIMENSIONS

	L x W x H	
	mm	inch
SF 1-6/2*-6*		
Pack & floor-mounted	760 x 690 x 840	29.9 x 27.2 x 33.1
Full Feature & floor-mounted	1025 x 690 x 840	40.4 x 27.2 x 33.1
Pack & 270l receiver	1275 x 690 x 1450	50.2 x 27.2 x 57.1
Full Feature & 270l receiver	1275 x 690 x 1450	50.2 x 27.2 x 57.1
Pack & 500l receiver	2055 x 690 x 1450	80.9 x 27.2 x 57.1
Full Feature & 500l receiver	2055 x 690 x 1450	80.9 x 27.2 x 57.1
SF 8*-22*		
SF 8*-11+	1670 x 750 x 1230	65.7 x 29.5 x 48.4
SF 15*-22+	1628 x 750 x 1844	64.1 x 29.5 x 48.4
SFD 11*-22*		
SFD 11*-22+	1628 x 750 x 1844	64.1 x 29.5 x 48.4
SF 1-4 Skid / SF 6-8 Twin		
SF 1-4 Skid FM	800 x 600 x 540	31.5 x 23.6 x 21.3
SF 1-4 Skid TM	1267 x 600 x 1154	49.9 x 23.6 x 45.4
SF 6-8 Twin	2043 x 600 x 1154	80.4 x 23.6 x 45.4



OPTIONS

	SF 1-6	SF 2*-6*
Integrated refrigerant dryer	•	•
CD adsorption dryer (only for Full Feature tank-mounted variants)	-	•
Phase Sequence Relay	•	•
Prefiltration kit	•	•
Integrated 30l air receiver + EWD	•	•
270l air receiver	•	•
500l air receiver	•	•
EWD on air receiver (only for tank-mounted variants)	•	•
Water Separator Drain (WSD) (only for Pack floor-mounted variants)	-	•
Upgrade to Mk5 Graphic Controller	-	•
ES4i & ES6i (only with Mk5 Graphic Controller upgrade)	-	•
Wooden package	•	•
Test certificate	•	•

	SF Skid/Twin
270l air receiver (SF Skid)	•
CD adsorption dryer (only for FF TM variants)	•

	SF 8*-11+	SF 15*-22+	SF 17*-22+
Integrated Refrigerant Dryer	•	•	•
EWD for compressor (Pack units only)	•	•	•
Extra module upgrade SF 8* to 15*	•	-	-
Extra module upgrade SF 11* to 17* & 22*	•	-	-
Extra module upgrade SF 17* to 22*	-	-	•
Main switch	•	•	•
Audible alarm	•	•	•
ES4i & ES6i	•	•	•
Wooden package	•	•	•
Test certificate	•	•	•

- : Not available • : Optional

COMMITTED TO SUSTAINABLE PRODUCTIVITY

We stand by our responsibilities towards our customers, towards the environment and the people around us. We make performance stand the test of time. This is what we call – Sustainable Productivity.



Atlas Copco

www.atlascopco.com/sf